

APPLICATION

Air Valve Vent Pole is used for venting air release valve pits and is suitable for venting applications designed to SEQ Water standards.

Product may be suitable for other water authorities subject to their approval.

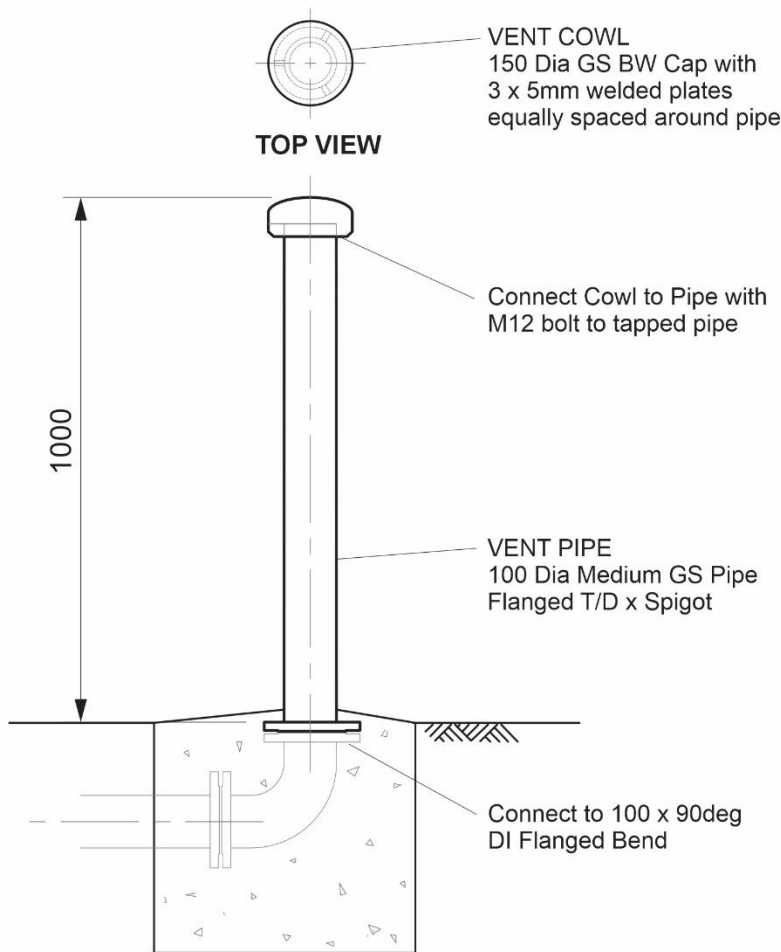

TECHNICAL

Installation, location and connections to be in accordance with the Water Authority's requirements.

Vent Pole has been designed by SEQ Water as per drawing SEQ-WAT-1304-1. The data contained in this data sheet is subject to change by the Water authority.

Coating: Heritage Green powder coating.

VENT POLE ARRANGEMENT

Source: SEQ Water Drawing SEQ-WAT-1304-1

ORDERING INFORMATION

DN	Description	Product Code
100	DN 100 Steel Vent Pole 1000 high Flanged T/D. Heritage Green	VAP

CIVILPIPES PTY LTD

ABN 30 168 566 667
2 Potassium St. Narangba Qld 4504
PO Box 304, North Lakes Qld 4509



Web:
civilpipes.com.au



Telephone:
+61 7 3053 3456



E-mail:
sales@civilpipes.com.au

