

FLANGE ISO MOUNT PN16

DN 150

APPLICATIONS

Betta Resilient seat gate valves comply with AS/NZS 2638.2 and are suitable for use in potable water, non-potable water and wastewater systems installed above ground and below ground.

The VGFI Series model with ISO flange is designed to be operated by a mounted gearbox actuator.

TECHNICAL DATA

Standard:	AS/NZS 2638.2 (Lic OMK25731) WSAA Product Appraisal 1121 – Betta Valves
Size Range:	DN 150
Pressures:	Operating Pressure 1600 kPa (PN 16) Test Pressure – Seal 1760 kPa Test Pressure – Body 2400 kPa
Temperatures:	Max 80 deg C, Max 40 deg C for potable water systems to AS 4020
Coating:	Fusion Bonded coating to AS/NZS 4158
End connections:	Flange (AS 4087, PN16)
Actuator Flange:	F10 ISO 5211 Flange
Closing options:	Anti-clockwise (ACC) and Clockwise closing (CC)
Options:	Handwheels or Gearbox actuators Extension spindles Restraint – Anchor Legs and SS Straps Alternate Flange drillings available on request



FEATURES

- High strength and corrosion resistant materials
- EPDM encapsulated ductile iron wedge ensures effective sealing
- Full bore design eliminates blockages
- Anti-friction components for lower operating torques
- Integrated cast in foot design provides stability
- Isolated fasteners are encapsulated with hot melt silicon coating
- Valve can be installed in either the vertical or horizontal position.
- 10 Year Manufacturer's Warranty against Defects.

COMPONENTS

ITEM	PART	MATERIAL	STANDARD
1	Body	Ductile Iron Gr 500-7	AS 1831
2	Wedge	Ductile Iron Gr 500-7, EPDM encapsulated	AS 1831 AS 1646
3	Stem Nut	DR Brass C48600	AS 1568
4	Stem	Stainless Steel Gr 431	ASTM A276
5	Bonnet Gasket	EPDM	AS 1646
6	Bolts – Bonnet, Gland & Stem Cap	Stainless Steel Gr 316	ASTM A276
7	Bonnet	Ductile Iron Gr 500-7	AS 1831
8	Gland ISO Flange	Stainless Steel Gr 316	ASTM A276
9	Stem Key	Stainless Steel	ASTM A276
10	O-Ring Seal	NBR	AS 1646
11	Thrust Washer	POM	AS 1646
12	Gland O-Ring	NBR	AS 1646
13	Washer	DR Brass C48600	AS 1568
14	Stem Seals	NBR	AS 1646
15	Thrust Collar	POM	AS 1646
16	Dust Cover	EPDM	AS 1646
17	Stem Cap	Ductile Iron Gr 500-7	AS 1831

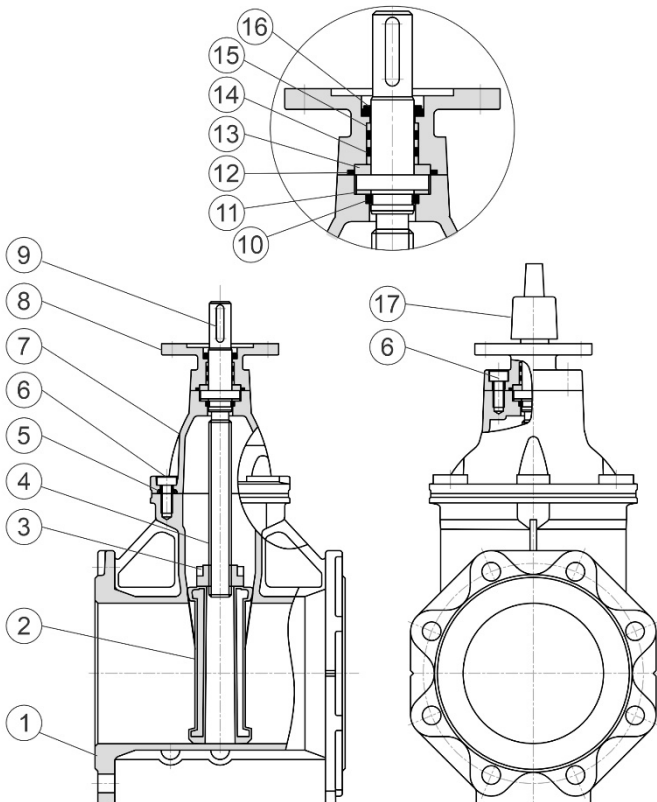

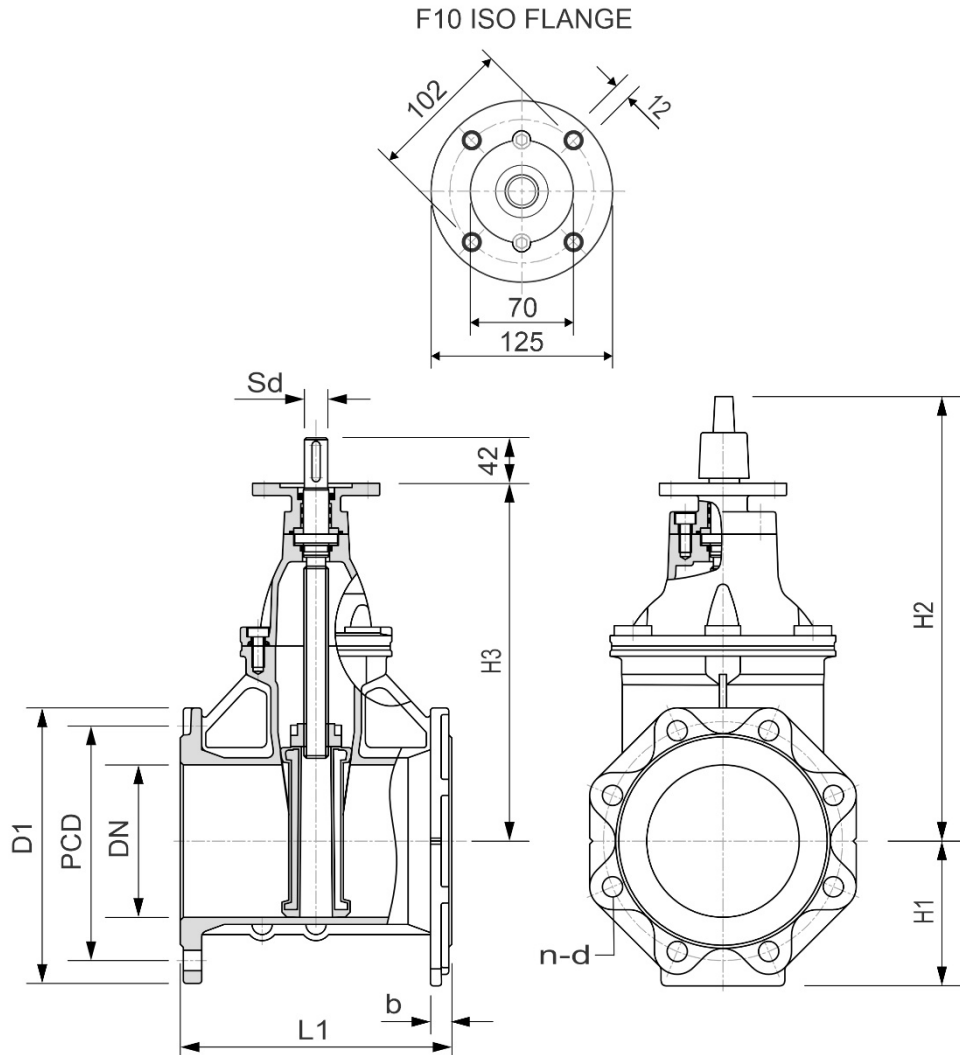

DIMENSIONS

DN	L1	H1	H2	H3	Sd	D1	PCD	n-d	b	No Turns	Torque In Nm	Weight kg	ACC	CC
150	267	130	420	358	22	280	235	8-18d	23	32	110	34	VGFI15	VGFI15C

CIVILPIPES PTY LTD

ABN 30 168 566 667
2 Potassium St. Narangba Qld 4504
PO Box 304, North Lakes Qld 4509



Web:
civilpipes.com.au



Telephone:
+61 7 3053 3456



E-mail:
sales@civilpipes.com.au

