

FLANGE ISO MOUNT PN16

DN 900

APPLICATIONS

Betta Resilient seat gate valve is designed and tested to comply with AS/NZS 2638.2 and the dimensions with EN558-1 Series 3.

This valve is suitable for use in potable water, non-potable water and wastewater systems installed above ground and below ground.

The VGFI Series model with ISO flange is designed to be operated by a mounted gearbox actuator.

TECHNICAL DATA

Standards:	AS 2638.2 Compliant (Design and Testing)
Dimensions:	EN 558-1 Series 3
Size Range:	DN 900
Pressures:	Operating Pressure 1600 kPa (PN 16) Test Pressure – Seal 1760 kPa Test Pressure – Body 2400 kPa
Temperatures:	Max 80 deg C, Max 40 deg C for potable water systems to AS 4020
Coating:	Fusion Bonded coating to AS/NZS 4158
End connections:	Flanges to AS 4087, PN16
Actuator Flange:	F25 ISO 5211 Flange
Closing options:	Anti-clockwise (ACC) and Clockwise closing (CC)
Options:	Handwheels or Gearbox actuators Extension spindles



FEATURES

- High strength and corrosion resistant materials
- EPDM encapsulated ductile iron wedge ensures effective sealing
- Full bore design eliminates blockages
- Anti-friction components for lower operating torques
- Integrated cast in foot design provides stability
- Isolated fasteners are encapsulated with hot melt silicon coating
- Valve can be installed in either the vertical or horizontal position.
- 10 Year Manufacturer's Warranty against Defects.

COMPONENTS

ITEM	PART	MATERIAL	STANDARD
1	Body	Ductile Iron Gr 500-7	AS 1831
2	Wedge	Ductile Iron Gr 500-7, EPDM encapsulated	AS 1831, AS 1646
3	Stem Nut	Alum Bronze C95210	AS 1565
4	Stem	Stainless Steel Gr 431	ASTM A276
5	Bonnet Gasket	EPDM	AS 1646
6	Bolts - Bonnet, Gland & Stem Cap	Stainless Steel Gr 316	ASTM A276
7	Bonnet	Ductile Iron Gr 500-7	AS 1831
8	Plug & O-Ring	SS Gr 316, EPDM	A276, AS 1646
9	Gland ISO Flange	Ductile Iron Gr 500-7	AS 1831
10	O-Ring Seal	EPDM	AS 1646
11	Bearing	Component	
12	Gland O-Ring	NBR	AS 1646
13	Bushing	Alum Bronze C95210	AS 1565
14	Stem Seals	EPDM	AS 1646
15	Dust Ring	EPDM	AS 1646
16	Lifting Points	Cast in Bonnet	
17	Stem Key	Stainless Steel	ASTM A276

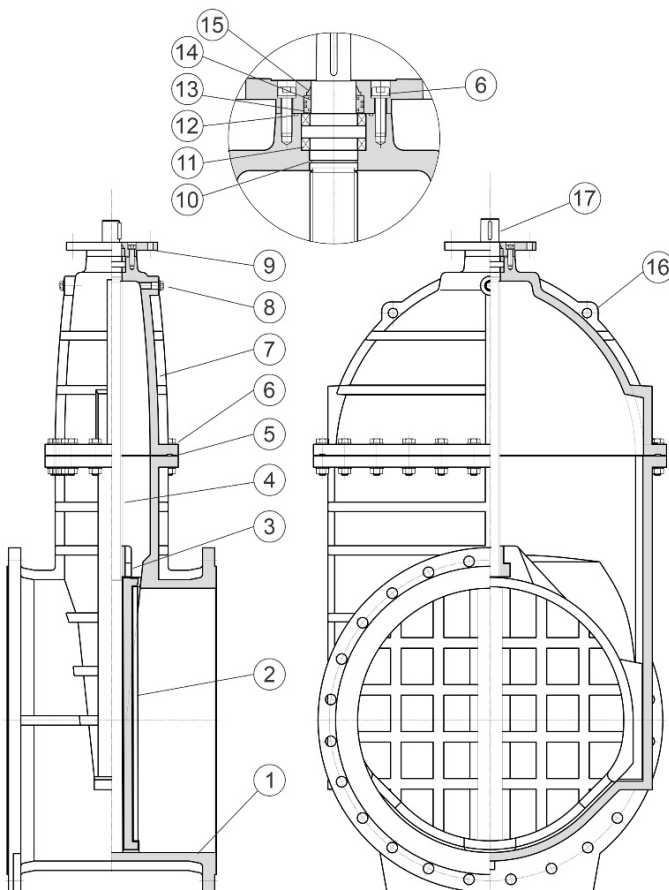

F25 ISO FLANGE

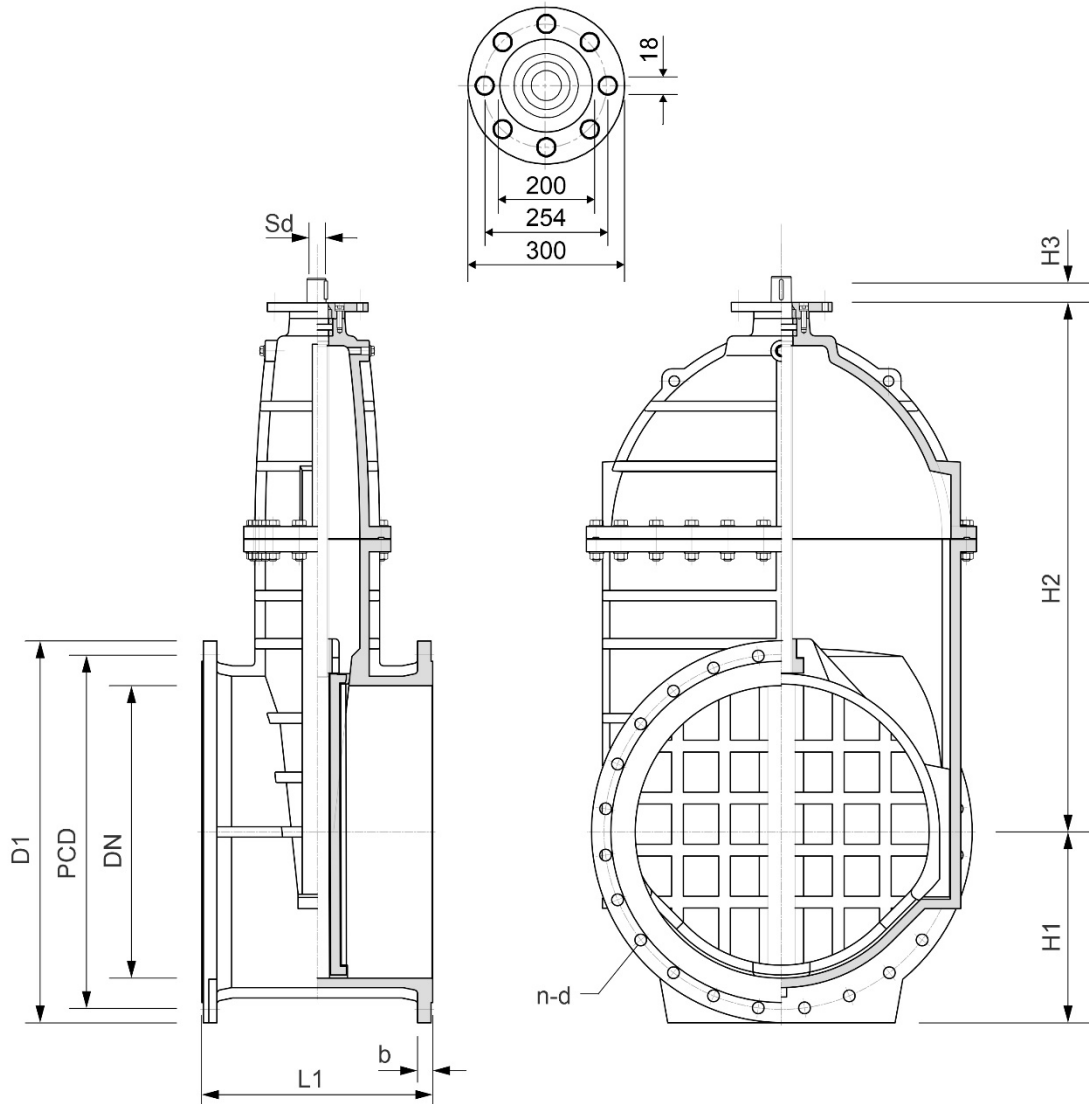

DIMENSIONS

DN	L1	H1	H2	H3	Sd	D1	PCD	n-d	b	No Turns	Torque In Nm	Weight kg	ACC	CC
900	711	588	1630	80	60	1175	1092	24-36d	47	57	936	1840	VGFI90	VGFI90C

CIVILPIPES PTY LTD

ABN 30 168 566 667
 2 Potassium St. Narangba Qld 4504
 PO Box 304, North Lakes Qld 4509



Web:
civilpipes.com.au



Telephone:
 +61 7 3053 3456



E-mail:
sales@civilpipes.com.au

